

Wolverine Brand Vapor Phase Adsorber
Model HDPE39
For Air Flows From 251 – 350 CFM



Wolverine Brand HDPE Adsorber

Our Model HDPE 39 is available as a stand alone Vessel or can come complete with Pressure Blower, Control Panel and a variety of Activated Carbons or Granular Potassium Permanganate to suit your particular air purification requirements. The Wolverine Brand HDPE 39 is available preassembled on an industrial skid or packaged as a kit for Onsite assembly.

General Specifications

Wolverine Brand Industrial Vapor Phase Adsorber Model HDPE39

Adsorber Vessel:

- Made of HDPE
- Height: Approx: 60 in (152 cm)
- Diameter: 39" (99 cm)
- Carbon Capacity
 - Regular Carbon: 700 lb (318 kg)
 - Caustic Carbon (Impregnated) : 875 lb (397kg)
 - Catalytic Carbon: 700 (318 kg)
- Inlet: 6 inch pipe, Outlet: 6 inch pipe
- Adjustable inlet Dampener for air flow adjustment.
- Upper lid is removable for easy carbon bed change out.
 - Lid is mounted utilizing Three ¼ 20 stainless steel bolts
- Magnehelic Differential Pressure Gauge model 2500
- Condensation drain
- Stainless Steel carbon bed grounding rod
- FRP Carbon Support Bed with Air Plenum
- Equipped with mounting tabs to secure to skid or cement slab.
- Vessels can be used as a stand alone adsorber or utilized in **Series (Treatment Train) or in Parallel**

Optional Accessories



Pressure Blower Model PB-10A

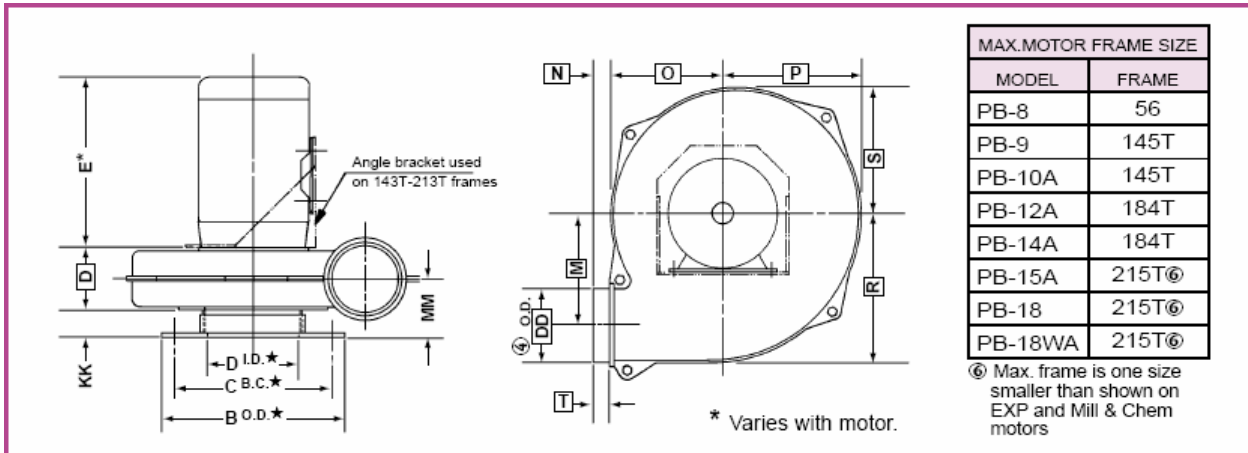

1. Cast aluminum, spark resistant, self-cleaning wheel
2. Horsepower: 1 HP
3. Motors are available in the following Voltages/ratings V/Phase/HZ
 - a. 115-239V/1/60
 - b. 208-239/460V/1/60
4. Motor Ratings: Wolverine Brand Vapor Phase Adsorbers are available with the following Motor ratings
 - a. TEFC (Totally Enclosed Fan Cooled) has external fan as an integral part of the motor, to provide cooling by blowing air around the outside frame of the motor.
 - b. EXP: Explosion-Proof Motors - These motors meet Underwriters Laboratories (UL) and Canadian Standards Association standards for use in hazardous (explosive) locations, as indicated by the UL label affixed to the motor. Locations are considered hazardous because the atmosphere does or may contain gas, vapor, or dust in explosive quantities.

Control Panel

1. Housing is of FRP Construction (Fiberglass Reinforced Plastic.)
2. Controls are manufactured by Moeller Electric
3. Available in the following configurations: Voltage/Phase/HZ
 - a. 115/1/60
 - b. 239/1/60
 - c. 208-239/3/60
 - d. 460/3/60
4. The following controls come as standard equipment on our control panels
 - a. Lockable disconnect
 - b. Run Light
 - c. 3 position switch, On/off/auto

Skid:

Utilizing our skid will save set up time as we will preassemble your Wolverine Brand Vapor Phase adsorber and accessories. Note: Price of Skid Includes \$450.00 Assembly fee of system.

1. Size: W42” L72”
2. We Utilize epoxy coated steel 2”x 4” channel, 12 gauge deck industrial skids
3. Built in fork slits for easy mobility of your Odor Scrubber
4. Price of skid includes assembly fee of your Vapor Phase Adsorber

Rain Hat:

Optional Rain hat comes with stainless steel bug/bird Screen

Activated Carbons and Potassium Permanganate:

All of our Odor Adsorbers are available with the following Media.. Click on links for specifics on all of our Carbons

- Coal Based Catalytic Activated Carbon-2 Varieties * **Best Carbons for H2S removal**
- Coal based Pelletized Activated Carbon- 3 Varieties
- Coal Based Impregnated Activated Carbon- 1 Varieties
- Coconut Shell Activated Carbons- 2 Varieties
- GRANULAR POTASSIUM PERMANGANATE.2 varieties

Simple Solutions Dist LLC
6 Jacobs Road
West Milford NJ 07480
973 846 7817

SimpleSolution1@optonline.net
www.stopsepticodor.com
www.industrialodorcontrol.com